

Quick Start Guide

Room Sync

1 Description

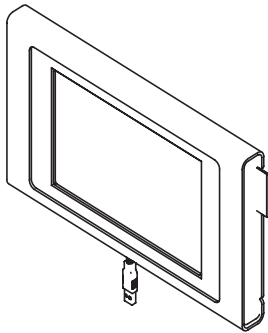

The following components are included:

A	Display unit (with USB connector and wall bracket)
B	Wall bracket
C	Power pin
D	Locking screws (display -> wall mount)
E	Screws (wall)
F	Plugs (wall)
G	USB-connector
H	Power adapter with USB-connection (selected markets)
I	Adhesive pad, double-sided, for glass mounting. Cleaner.

2 Setup - on/off & configuration

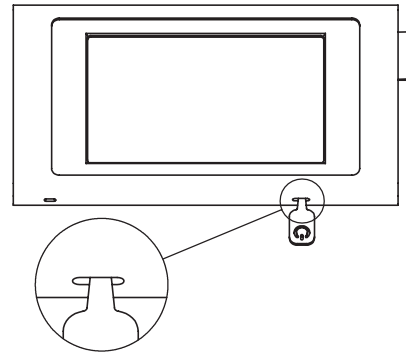

Power up the unit by connecting the USB-connector to the USB-adapter.

WARNING: DO NOT EXTEND THE USB-CABLE OR REPLACE THE ORIGINAL USB-ADAPTER.

Access the unit's power button by using the "Power pin" as shown in the illustration. Press and hold down the button for a few seconds until the unit responds. To turn off: use the same method as outlined above.

Booting the device can take several minutes. Follow on screen instructions and prompts.

! To get started with ROOM SYNC/Room Display 5, you need to register your display unit(s). For this, you need one license key per device.

How do I get my license key(s) and register unit(s)?

- 1) Follow instructions and register for a user account at www.roomdisplaycenter.com
- 2) Redeem voucher(s) - When you order ROOM SYNC, you get a voucher with your license key(s) (from seller, eg electronically)
 - A voucher can contain any number of license keys

Need support?
1) Contact seller 2) www.gogetcorp.com -> FAQ or www.roomdisplaycenter.com

3 Mounting instructions

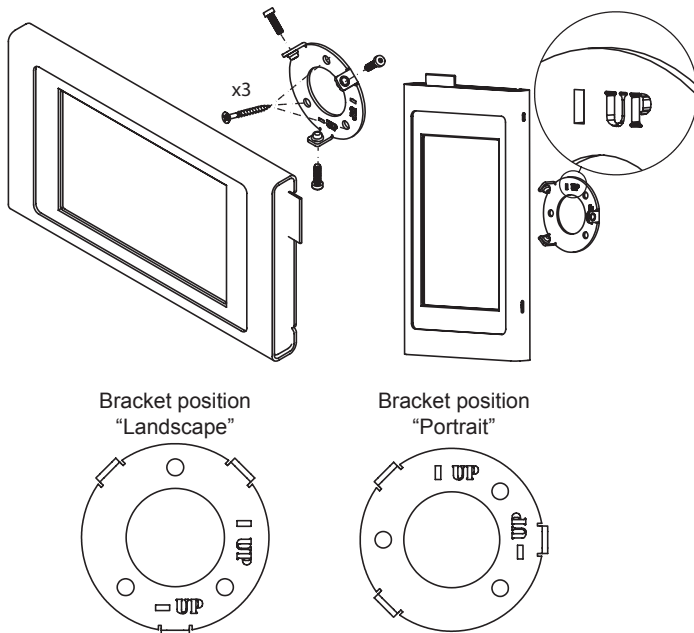

To mount Room Sync on the wall, follow these steps:
Remove the wall bracket from the unit. Keep the screws in a secure place.

-Landscape mode: Place the bracket on the desired wall. The symbol for landscape should be horizontal with the wording "UP" easily readable.

-Portrait mode: Place the bracket on the desired wall. The symbol for portrait should be vertical with the wording "UP" easily readable.

-Mark (and drill) 3 holes, use plugs if necessary and use the 3 wall screws to secure the bracket.

-For fitting on glass: Clean the glass and bracket surfaces carefully with the supplied surface cleaner sachet. Remove one cover and place the adhesive pad over the bracket, press firmly. Then remove the other pad cover, position correctly on the glass wall and press firmly.

-Place the display unit over the bracket in the required alignment and then secure with the 3 locking screws as shown in the illustration.

Note! The power/USB cable must go through the designated 4th hole on the back of the unit. Alternatively, the cable can directly go through the wall bracket and into a hole in the wall. **Do not extend the USB-cable or replace the original USB-charger.**

4 Troubleshooting

If you run into any problem with your product, please follow these instructions:

Problem	Action required	Comment
All problems related to system configuration (Exchange or Google Apps)	Please contact the system administrator. (IT-department within your organization, alternatively an IT consultant/IT professional)	This is quite common. However, since the hardware and software work properly, you need support from the system administrator
Problems related to Room Display software, eg registration issues, crashes etc.	Contact the seller. Please see our Support/Wiki/FAQ at gogetcorp.com or roomdisplaycenter.com . If that does not help, contact Goget for support.	See Goget's Terms & Conditions/EULA at gogetcorp.com
All problems related to physical hardware.	Contact the seller. Direct sales: Contact Goget at gogetcorp.com for further instructions. Do not attempt to disassemble the unit unless instructed specifically to do so, and by following exact instructions.	See Goget's Terms & Conditions at gogetcorp.com .